



B+S BLACK SERIES: IN-SP1-12

Single Hole Induction Stock Pot - 12 Kilowatt

Project: _____ Item: _____



Standard Features:

- AISI Grade Stainless Steel
- Heavy duty complete stainless steel frame
- One-piece machine pressed top deck - 1.5mm Thick
- Seamless micro glass top - 435mm
- IPProfessional cooking system incorporates high performance
- High frequency heating coil and magnetic aggregation technology
- Isolated bottom ensures safety and reliability
- Rotary lever handle allowing up to 8 different heating levels
- Automatic detection cookware system ensures safer cooking
- IP65 rated LED dot matrix display
- Front access to all components makes service easy
- Stock pot with release valve - 170 L (600mm dia x 600mm H)

Options:

- High Splashback - IN-SP1-12-HS

Specifications:

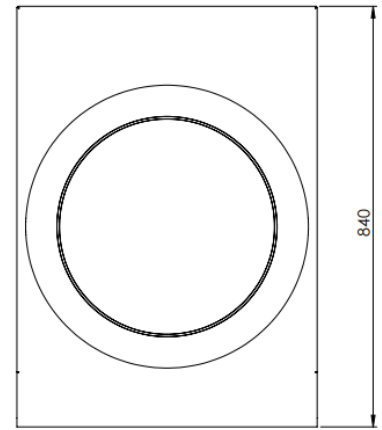
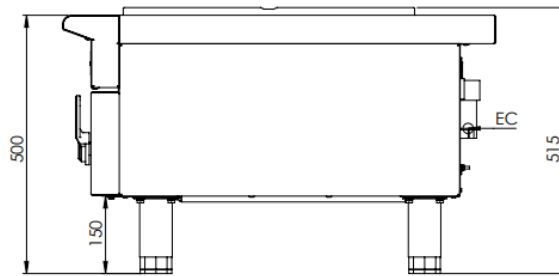
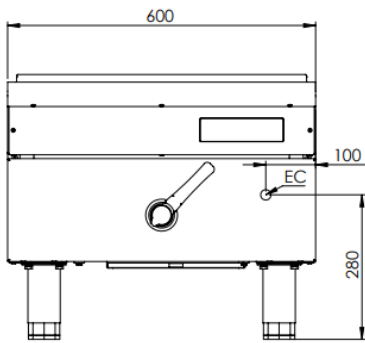

MODEL	LENGTH (mm)	DEPTH (mm)	HEIGHT (mm)	NET WEIGHT (kg)
IN-SP1-12	600	840	515	42.5

Connections:

ELECTRICAL CONNECTION (EC)	ELECTRICAL SUPPLY REQUIREMENTS						
	VOLTAGE (V)	TYPE	FREQUENCY (Hz)	POWER (kW)	L1 AMPS (A)	L2 AMPS (A)	L3 AMPS (A)
Hard Wired	415	3P+N+E	50/60	12	18.5	18.5	18.5

- **Must** be installed by an authorised installer in accordance to **AS/NZS 3000 refer to current version**

Due to ongoing Product Development, Product Improvement and Research, B+S Commercial Kitchens reserves the right to alter specification without notice.

Electromagnetic Compatibility: AS/NZS CISPR 14.1, EN IEC 55014-1:2021

