

840

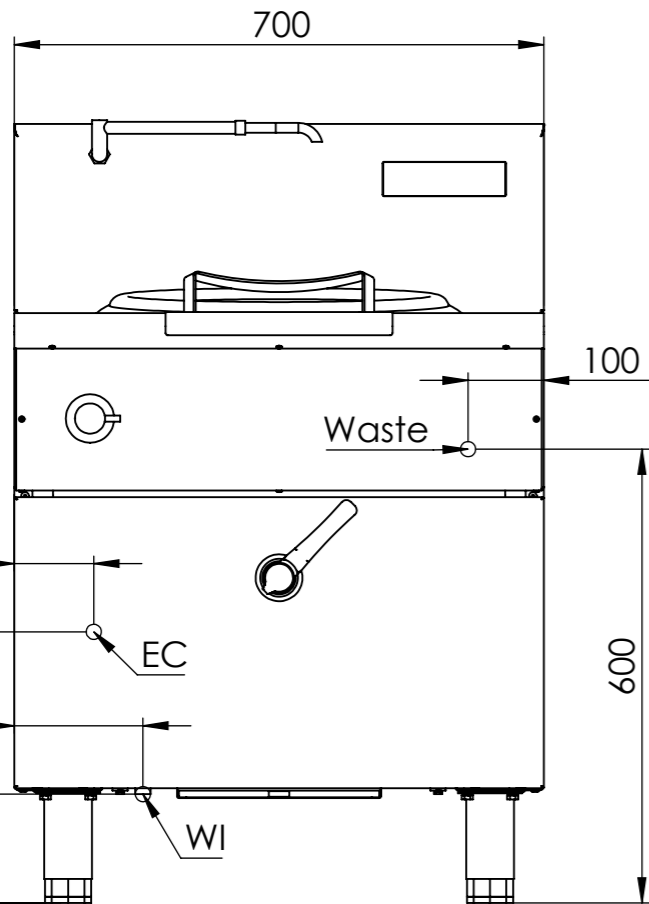

Waste

100

EC

170

105

145

WI

600

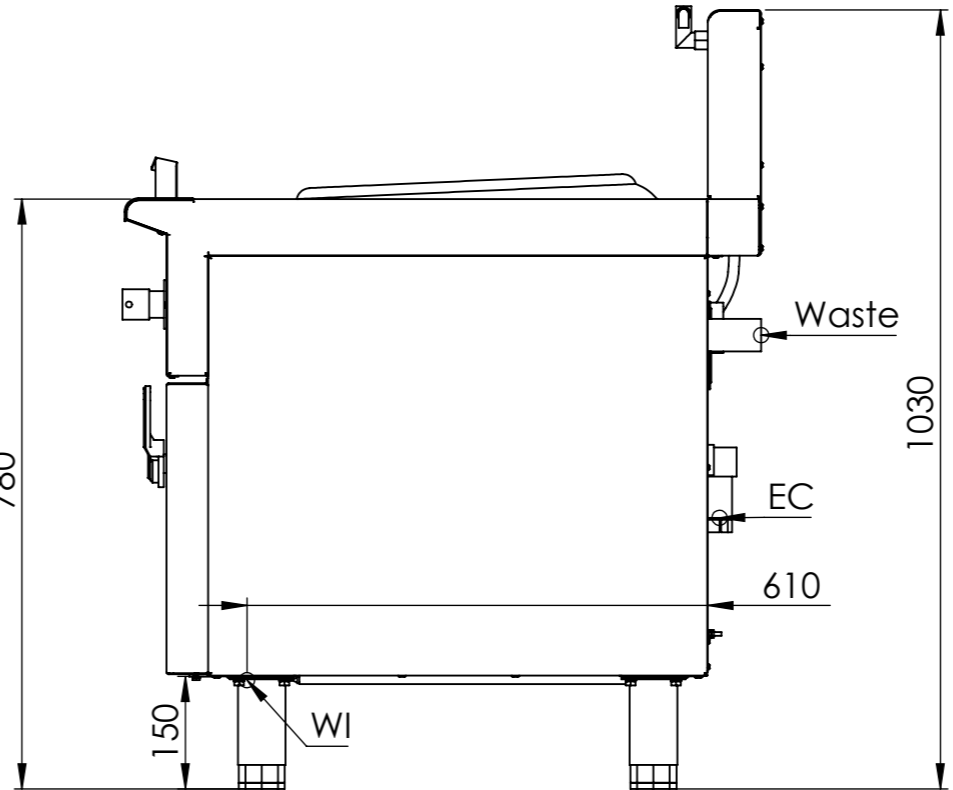

Waste

EC

610

780

1030

150

WI

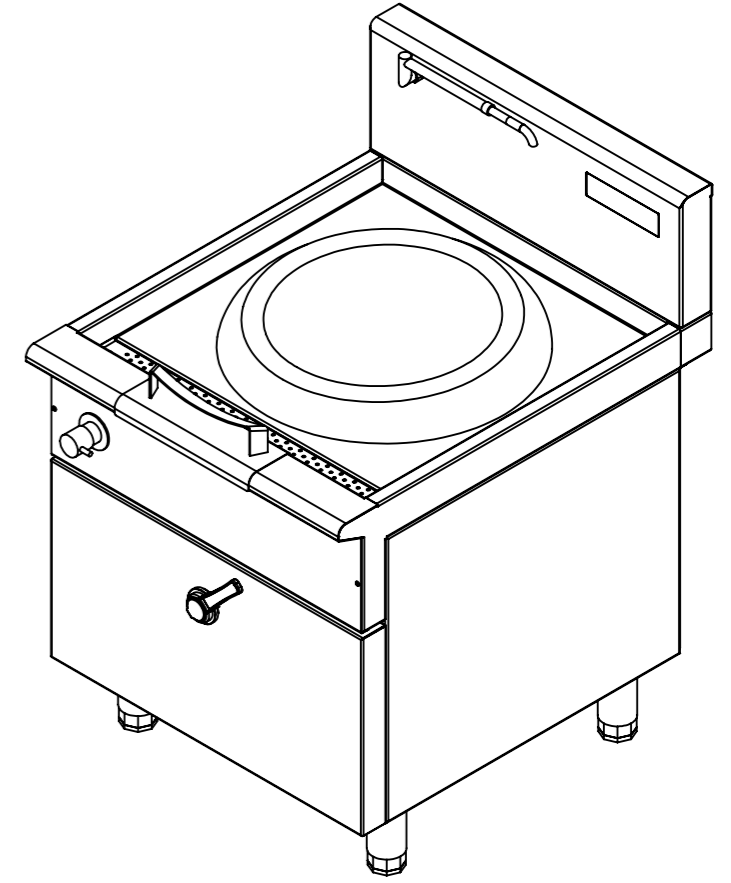

**NOTE**

WI = 1/2" Threaded SS Pipe  
 Waste = PVC Pipe DWV 40mm  
 EC = Electrical Connection: 12kW, 3N 415V, 50Hz, 18.5A

**UNLESS OTHERWISE SPECIFIED:**  
 1. DIMENSIONS ARE IN MILLIMETRES  
 2. TOLERANCES:  
 LINEAR: +/- 1mm  
 ANGULAR: +/- 0.30°  
 3. BEND RADIUS 2mm. ALL BENDS AT 90°

**SURFACE FINISH:**  
 1. NATURAL (LEAVE FILM INTACT FOR DELIVERY).  
 2. NO BLEMISHES OR SCRATCHES ON BASE METAL.  
 3. REMOVE ALL BURRS AND SHARP EDGES.



DO NOT SCALE DRAWING REVISION: -

**B & S Commercial Kitchens**  
 57 Plateau Road, Reservoir Victoria, 3073  
 Tel.: (03) 9469 4754 / Fax: 9469 4504

	NAME	SIGNATURE	DATE	
DRAWN	S.K		20/05/2024	
CHK'D				Thickness (mm):
APPV'D				MATERIAL:
MFG				
Q.A				
				WEIGHT:

TITLE:		<b>IN-W1-12</b>	
DWG NO.		A3	
SCALE: 1:10		SHEET 1 OF 1	