



VERRO SERIES: VTT-9-BM

900mm Bench Mounted Target Top

Project: _____ Item: _____



Standard Features:

- AISI Grade Stainless Steel
- Heavy duty complete stainless steel frame
- 42MJ dual ring cast iron burner
- Three piece heavy duty machined cast iron top with removable center ring
- Internal lining consisting of thermal insulating refractory bricks that offers low heat conductivity and integral spill protection
- Surface cooking area - 900mm W x 620mm D
- Flame Failure - Included as standard
- Manual ignition to pilot dual ring cast iron burner
- Center ring removal tool is provided
- Multi-setting gas valve – Allows greater regulation of flame setting
- Easy access to all components for servicing and adjustments
- Easy to clean fat spillage tray

Options:

- Natural or LPG Gas

Specifications:

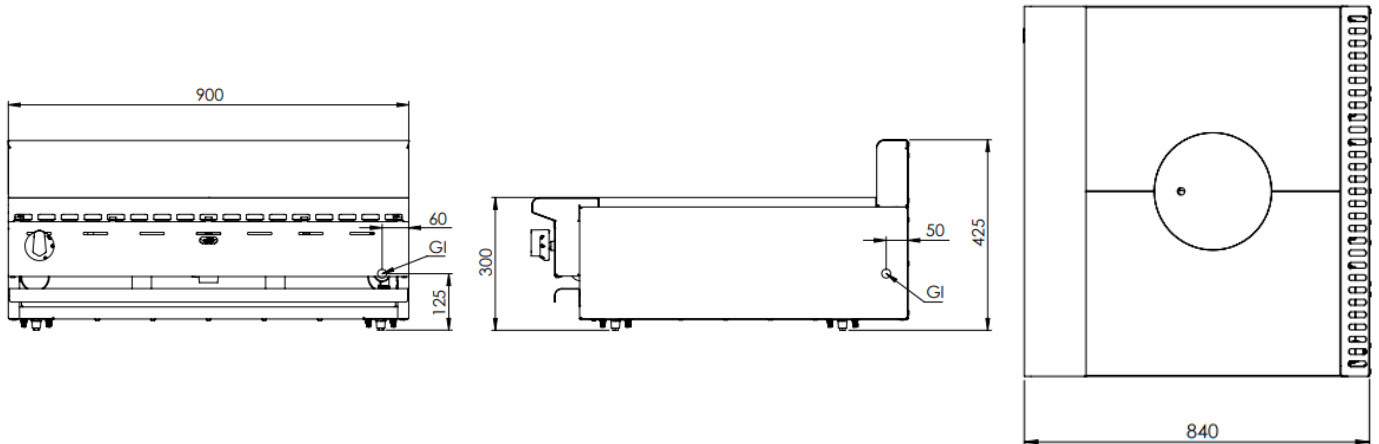

| MODEL | LENGTH (mm) | DEPTH (mm) | HEIGHT (mm) | NET WEIGHT (kg) | GAS CONSUMPTION (Mj/h) | |
|----------|-------------|------------|-------------|-----------------|------------------------|-----|
| | | | | | NG | LPG |
| VTT-9-BM | 900 | 840 | 425 | - | 42 | 42 |

Connections:

| GAS (GI) (BSP) | SUPPLY PRESSURE (kPa) | |
|----------------|-----------------------|-----|
| | NG | LPG |
| 3/4" (M) | 1.0 | 2.6 |

- Gas regulator is included with the unit
- **Must** be installed by an authorised installer in accordance to **AS/NZS5601** refer to current version

Due to ongoing Product Development, Product Improvement and Research, B+S Commercial Kitchens reserves the right to alter specification without notice.

Approval Number: GMK 10686



B+S Commercial Kitchens
57 Plateau Road Reservoir VIC 3073 Australia | +61 3 9469 4754
info@bscommercialkitchens.com | www.bscommercialkitchens.com

