



INSTALLATION, OPERATING AND SERVICING INSTRUCTION MANUAL



UFWWSP Series Commercial Stock Pot / Boiling Top Model No's.: UFW-W-D-SP-1/2/3-CB-LS

Approval No: GMK 10701

B&S Commercial Kitchens Pty Ltd

57 Plateau Road Reservoir VIC 3073 AUSTRALIA

Tel: +61 3 9469 4754 Fax: +61 3 94694504 Web: www.bscommercialkitchens.com

Please ensure this booklet is kept in a safe and prominent location for future reference.

The reproduction on or copying of any part of this booklet via any means is strictly forbidden unless agreed to in writing by the manufacturer.

Owing to continual product development and improvements to its products, B&S Commercial Kitchens Pty Ltd reserves the right to change the product specifications and design without prior notice.

Table of Contents

INSTALLATION, OPERATING AND SERVICING INSTRUCTION MANUAL	1
UFWWSP Series Commercial Stock Pot / Boiling Top	1
Product Specifications & Introduction	4
Table 1: Nominal Terminal Input Rates & Injector Sizes	4
Table 2: Standard Model General Information.....	5
Figure 1: Plumbing Connections:- UFWWSPK-1	5
Table 3: Plumbing Connections.....	5
Figure 2: Plumbing Connections:- UFWWSPD-1	5
Table 4: Plumbing Connections.....	6
Figure 3: Plumbing Connections:- VUFWWSP-1	6
Table 5: Plumbing Connections.....	6
IMPORTANT WARNINGS.....	6
Installation Instructions	7
Regulations.....	7
Data Label	7
Ventilation	8
Combustible Surfaces	8
Gas Connection	9
Pressure Test Point	9
Water Connection	9
Before Leaving - Commissioning.....	9
Operating Instructions	10
IMPORTANT WARNING!.....	10
Lighting Instructions.....	11
Shutdown Procedure	11
Telescopic Laundry Arm – Manual Control (Water Cooled Models).....	11
IMPORTANT WARNING!.....	11
Telescopic Laundry Arm Operation with Knee Valve – Where Fitted	11
IMPORTANT WARNING!.....	11

Maintenance and Care	11
Servicing Instructions	12
Abnormal Operation	12
Gaining Access to Gas and/or Water System	12
Removal of Burner for Service	13
Pilot and Flame Safeguard	13
Adjustments	13
Servicing Wok Spout – Where Fitted.....	13
Servicing Knee Valve – Where Fitted.....	13
Gas Type Conversion	13
Table 5: Troubleshooting	14
STANDARD WARRANTY CONDITIONS	15

Product Specifications & Introduction

Appliance Name: UFWWSP Series Commercial Stock Pot Table
This appliance may be branded as B&S, K plus and Verro

Manufactured By: Certificate Holder:	B&S Commercial Kitchens Pty Ltd 57 Plateau Road Reservoir Victoria 3073 Tel; + 61 3 9469 4754 Fax: +61 3 9469 4504 E-mail: info@bscommercialkitchens.com
Model Number/s:	<p>How to read model numbers; <u>(V)UFW-W-D(K)-SP-1/2/3-CB-LS-P-LR</u> θ ω ε ρ τ ψ υ</p> <p>θ UFW = Unflued Table (All Models) ω W = Waterless Model – Where Applicable ε D = Deluxe Model – Stainless Steel Chassis (where applicable) ρ SP = Stock Pot Table V at the beginning indicates Verro model. K indicates K plus model.</p> <p>Number of stock pot holes 1 - Single Hole 2 - Two Holes 3 - Three Holes</p> <p>Burner type/s τ CB = Chimney Burner ψ LS = Low Splashback – Where Applicable υ P = Plinth Mount (only for Verro units) υ CBM = Cabinet base mounted LR = Large 17" ring(1-4)</p> <p>E.G. UFWW – SP – 2 – CB – LS Is a waterless stock pot model, with two holes, two chimney burners and</p>
Approval Number:	GMK 10701
Gas Types:	Natural Gas and Propane Gas

We are confident that you will be delighted with your B&S stock pot, and that it will become the backbone of your kitchen. To ensure you receive the utmost benefit from your new B&S appliance, there are two important things you can do.

1. Ensure you read this booklet carefully and carefully follow the instructions given. Ensure that this booklet is kept in a safe and prominent location for future reference.
2. Should you be unsure of any aspect of the operation/performance, servicing and installation of the appliance, please contact your B&S dealer immediately. In most instances a phone call could answer your question.

Table 1: Nominal Terminal Input Rates & Injector Sizes

Burner Type	Gas Type	Injector Size (mm)	MJ/h per Burner	Test Point Pressure
Duck Bill Burner (DB)	Natural Gas	1.40 mm (x18)	126	1.00 kPa
	Propane Gas	0.70 mm (x18)	90	2.60 kPa
Chimney Burner (CB)	Natural Gas	0.95 mm (x24)	105	1.00 kPa
	Propane Gas	0.55 mm (x24)	75	2.60 kPa

Please note that the minimum gas inlet pressure should be at least 1.13KPa (Natural Gas) and 2.75KPa (Propane). Gas pressure must be checked when all other equipment on the same line is turned ON high.

Table 2: Standard Model General Information

	Weight (kg)	Overall Height (mm)	Overall Depth* (mm)	Overall Width* (mm)
UFW/WSP-1	100	1,300	840	600
UFW/WSP-2	200	1,300	840	1,200
UFW/WSP-3	300	1,300	840	1,800
VUFWWSP-1	100	1030	840	600
VUFWWSP-2	200	1030	840	1200

Overall Dimensions – Custom made appliances

Height over splashback : 570mm - 1,300mm + adjustable legs.
 Width : 1,800mm minimum with 3 stock pots.
 Depth : 840mm minimum.

Figure 1: Plumbing Connections:- UFWWSPK-1

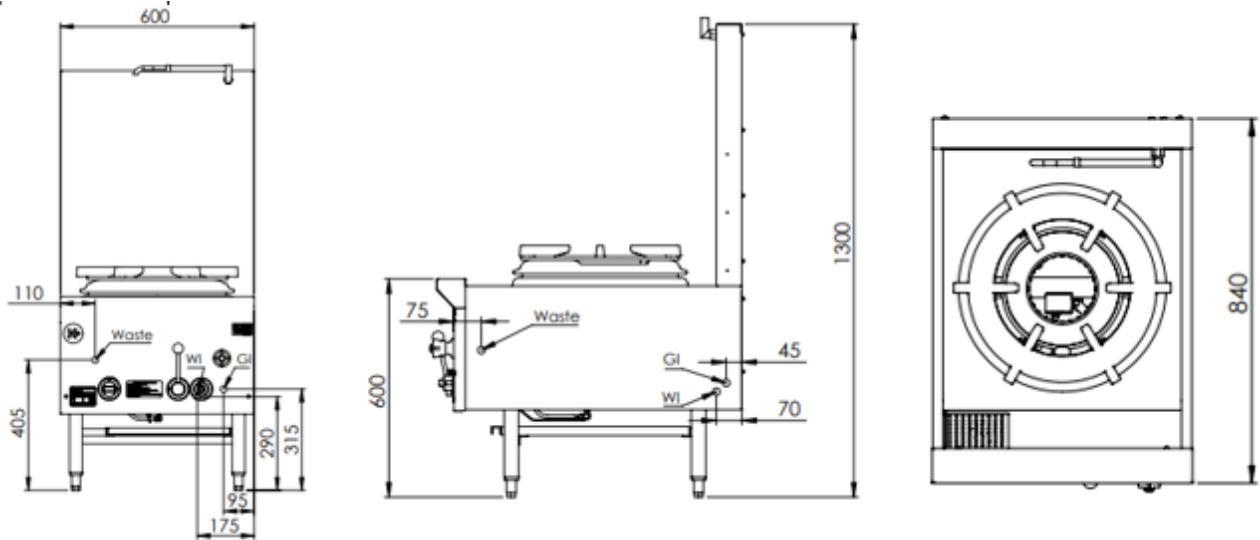

Table 3: Plumbing Connections

	Connection	Position from Floor (mm)	Position from Rear of Appliance (mm)	Position from LHS/RHS edge of Appliance (mm)
Water Inlet (WI)	½" Copper	290 (+/-5)	70 (+/-5)	170 (+/-5)
Gas Inlet (GI)	¾" male BSP	320 (+/-5)	45 (+/-5)	95 (+/-5)
Water Outlet/Waste (D)	2" BSP	410 (+/-5)	770 (+/-5)	110 (+/-5)

Figure 2: Plumbing Connections:- UFWWSPD-1

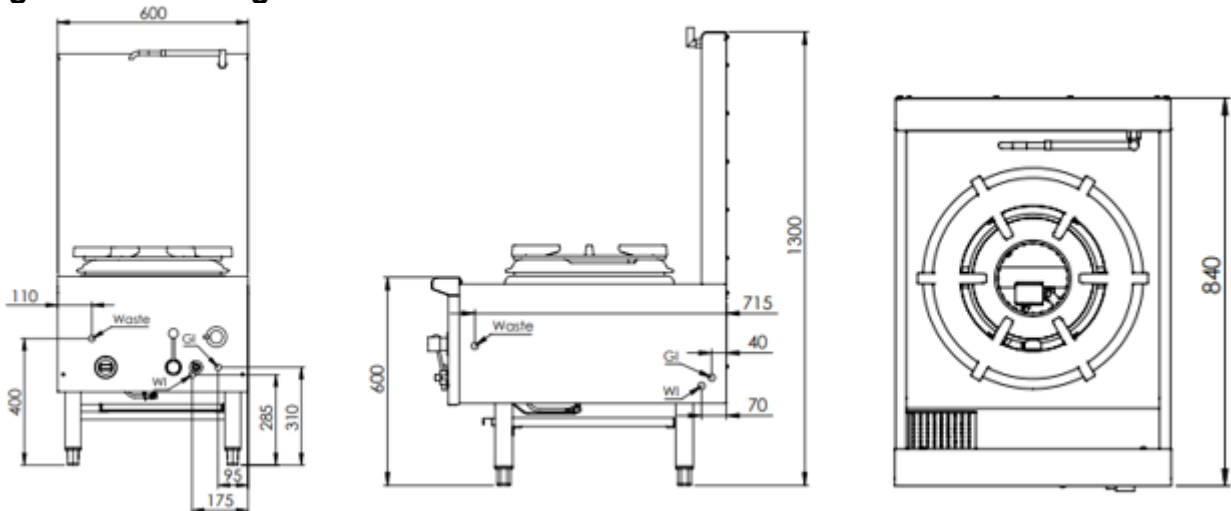

Table 4: Plumbing Connections

	Connection	Position from Floor (mm)	Position from Rear of Appliance (mm)	Position from LHS/RHS edge of Appliance (mm)
Water Inlet (WI)	½" Copper	290(+/-5)	70 (+/-5)	170 (+/-5)
Gas Inlet (GI)	¾" male BSP	320 (+/-5)	45 (+/-5)	95 (+/-5)
Water Outlet/Waste (D)	2" BSP	410 (+/-5)	770 (+/-5)	110 (+/-5)

Figure 3: Plumbing Connections:- VUFWWSP-1

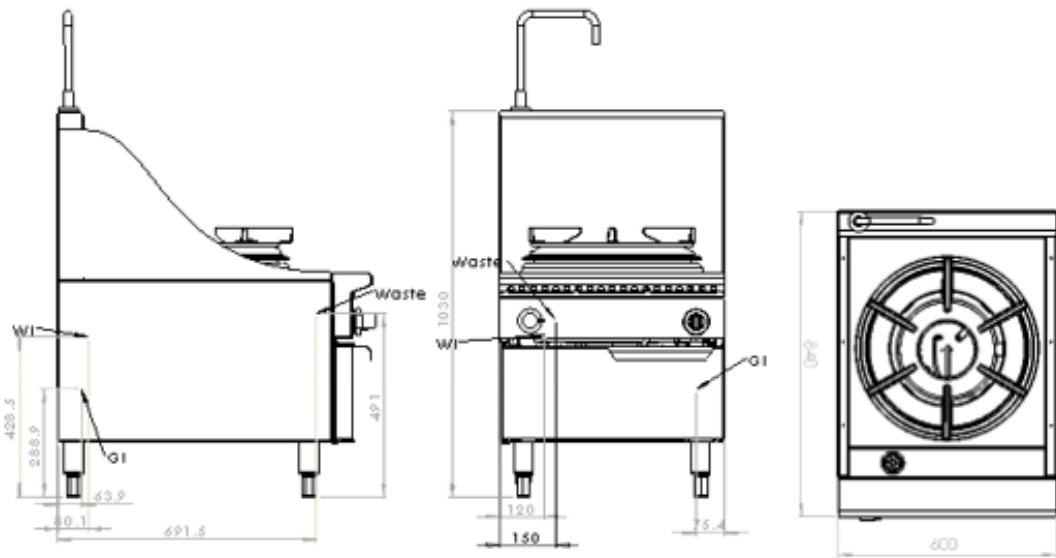

Table 5: Plumbing Connections

	Connection	Position from Floor (mm)	Position from Rear of Appliance (mm)	Position from LHS/RHS edge of Appliance (mm)
Water Inlet (WI)	½" Copper	430(+/-5)	80 (+/-5)	120 (+/-5)
Gas Inlet (GI)	¾" male BSP	290 (+/-5)	65 (+/-5)	75 (+/-5)
Water Outlet/Waste (D)	2" BSP	490 (+/-5)	690 (+/-5)	150 (+/-5)

IMPORTANT WARNINGS



THIS APPLIANCE SHALL ONLY BE INSTALLED/SERVICED BY AN AUTHORISED INSTALLER.

THIS APPLIANCE MUST BE INSTALLED IN ACCORDANCE WITH THE SPECIFIED INSTRUCTIONS AND SPECIFICATIONS.

IMPROPER INSTALLATION OR OPERATION OF THIS APPLIANCE MAY RESULT IN PRODUCT FAILURE WHICH MAY LEAD TO PROPERTY DAMAGE, PERSONAL INJURY OR DEATH.

CAUTION MUST BE TAKEN WHEN OPERATING THIS APPLIANCE TO MINIMISE RISK OF FIRE. THE APPLIANCE MUST NOT BE LEFT ON UNATTENDED.

REGULAR INSPECTIONS BY AN AUTHORISED SERVICE PERSON ARE STRONGLY RECOMMENDED TO ENSURE PROPER AND SAFE FUNCTIONING OF THIS APPLIANCE.

AFTER ANY SERVICING OR ADJUSTING OF GAS CONNECTED COMPONENTRY, GAS LEAK TEST

MUST BE CARRIED OUT TO ENSURE THERE ARE NO GAS LEAKING HAZARDS.

NEVER STORE ANY FLAMEABLE LIQUIDS/VAPOURS IN VICINITY OF THIS APPLIANCE. NEVER SPRAY AEROSOLS IN THE VICINITY OF THIS APPLIANCE WHILE IT IS IN OPERATION.

ENSURE ANY TRANSIENT PROTECTION IS REMOVED BEFORE INSTALLING THE APPLIANCE ENSURING ANY POSSIBLE DAMAGE TO THE APPLIANCE OR COMPONENTS/ PARTS THAT MAY HAVE BEEN SUSTAINED DURING TRANSPORTATION IS REPORTED TO THE MANUFACTURER.

THIS APPLIANCE IS NOT INTENDED TO BE USED IN A MARINE ENVIRONMENT. ENSURE APPLIANCE IS INSTALLED IN A STABLE POSITION.

FAILURE TO FOLLOW THE INFORMATION PROVIDED IN THIS BOOKLET WILL VOID THE B&S WARRANTY AND MAY RESULT IN DAMAGE TO EQUIPMENT OR INJURY TO PERSONNEL.

Please note that checking and adjusting of burner pressures on commercial catering appliances is an obligation of gasfitters.

The relevant legislation is as follows from the **Plumbing Regulations 2008** administered by the **Victorian Building Authority**:

Gas fitting work defined

- (1) Gas fitting work is the construction, installation, replacement, repair, alteration, maintenance, testing or **commissioning** of any pipe, **appliance**, flue, fitting, apparatus, control or other item that is involved with the supply or use of gas and that is fitted downstream of the outlet of a customer billing meter or a consumer's gas storage container

As per **AS/NZS5601.1**, clause 6.11.1, this gas appliance must be **commissioned** by a suitably authorized person who;

- (a) Installed the appliance when gas is available at the time of installation; or
- (b) Makes gas available to the appliance if gas was not available at the time of installation

As per **AS/NZS5601.1**, clause 6.11.3, the commissioning of this appliance shall take **full account of special design features, the manufacturer's instructions and the appliance safety requirements.**

As per **AS/NZS5601.1**, clause 6.11.4, the commission of this appliance shall include all of the following;

- (a) **Testing and purging** of the appliance and installation as appropriate.
- (b) Checks to ensure the appliance is in **safe working order.**
- (c) Ignition of each **burner** of the appliance and where necessary adjustment, in accordance with the **manufacturer's instructions.**
- (d) Testing of **flue** performance.
- (e) Testing of all **safety devices** for correct operation.
- (f) **Instruction** of the consumer, where available, on the safe and correct operation of the appliance and any auxiliary equipment.
- (g) Handing of the appliance **operating instructions** to the consumer, or if the consumer is not present, leaving the instructions in a suitable location on the premises.

Installation Instructions

Regulations

The appliance **must** be installed only by authorised persons and in accordance with the manufacturer's installation instructions, local gas fitting regulations, municipal building codes, AS 5601 – Gas Installations and any other health and safety regulations, local authority, gas, electrical any other statutory regulations.

Data Label

The data label is located on the front of the appliance. This appliance is suitable for Natural Gas and LPG. Please ensure that the gas supply matches the Data Label ensuring that the gas supply is correct for the appliance being installed and that adequate supply pressure and volume is available – refer to appliance data plate for MJ/h consumption, injector sizes of main burners/pilots, etc.

Ventilation

This appliance should always be installed under an extraction hood. Ventilation must be in accordance with AS5601 - Gas Installations. In general, the appliance should have adequate ventilation for complete combustion of gas, proper ventilation and to maintain temperature of immediate surroundings within safe limits. It is **compulsory** that this appliance is installed under an extraction hood.

The appliance shall be installed with an exhaust system comprising a hood and duct system. The hood shall be made of a material which is impervious to fat, grease and vapour. It shall be constructed so it can be readily and efficiently cleaned. Its inside faces shall be smooth and free of obstructions and all joints shall be grease tight.

The hood shall be located so as to effectively ventilate the steamer and shall extend at least 150 mm beyond the perimeter of the stock pot. The exhaust duct system shall be adequately sized and shall not get connected to any other ventilating or exhaust system.

As suitable grease trap shall be provided to prevent grease vapour entering the exhaust system and shall be located to avoid constituting a fire hazard and be readily accessible for regular cleaning.

Unless adequately protected a hood and a duct shall be fitted at least 450 mm from any combustible material and so that the lower edge of the grease filter is no less than 1.35 meters above the cooking surface. (please refer to AS/NZS 5601 clause 6.10.2.2 to verify clearances for ventilation.)

B&S units can be installed in a domestic environment provided the installation is strictly in accordance with the manufacturer's instructions and as per the AS/NZS5601.1 (please refer to the latest version when released). The installation of the unit must comply with clauses 6.2.4, 6.10.2 and 6.10.1.15 and an exhaust system shall be installed according to AS1668.1 and AS1668.2 interlocked to the gas supply. B&S shall not be responsible for any unauthorized and/or non-compliant installations and will void the warranty.

Combustible Surfaces

Clearances to combustible surfaces must be in accordance with AS/NZS 5601.1 - *Gas Installations*, clause 5.12.4.5. Install on a flat/level floor. Where the floor is not fire resistant, a fire resistant material shall be put under the appliance which shall have a fire resistance rating at least equal to that of 10mm millboard. The material shall extend at least 50mm beyond the edge of the appliance.

Leave a clearance of at least 200mm between the appliance and any combustible surface.

Please refer to table 6.9 and 6.10 in AS 5601.1. clause 6.10.2.2 and 6.10.2.3. Table 6.10 (2013 version) is given below. (Please refer to the latest version when released)

MINIMUM CLEARANCE AROUND COOKING SURFACE AREA

The clearance to combustible surfaces from commercial catering equipment shall be as specified in the appliance manufacturer's instructions and shall not be less than the clearance specified in the table below.

	Cooking surface area	Minimum clearance in mm
A	Above the cooking surface of a gas appliance	600
B	Subject to C from a cooking surface area having an open flame cooking appliance and no means of preventing cooking vessels from overhanging the edge of the gas appliance	250
C	From the side of a cooking appliance where the combustible surface is at least 100mm below a cooking surface area	50
D	From a gas appliance flue way or rear of the gas appliance with a splashback	50
E	From the rear or side of a gas appliance which is not an open flame gas cooking appliance	50

Notes:

1. The cooking surface area is defined as being that part of the gas appliance where cooking normally takes place and does not include those parts of the gas appliance containing control knobs.
2. These clearances do not apply where an adjacent surface is of a non-combustible material or is combustible but protected with a fire-resistant material. The fire-resistant material may be covered by ceramic tiles or stainless steel to meet appropriate requirements relating to health protection.
3. Care should be taken where a combustible surface is covered by a non-combustible material for example, covering a combustible surface with stainless steel will not prevent heat transfer, and in some circumstances hazardous situation could arise.

Gas Connection

The gas connection is male 3/4" BSP and is situated at the rear of the appliance below the main body frame. The number of gas inlets corresponds to the number of stock pot support rings the appliance is fitted with. The inlet is to the 3/4" elbow located at the rear of the appliance.

This appliance is available in models for fixed installation or in models fitted with lockable wheels/castors.

The appliance must be connected with rigid pipe as specified in AS5601. For fixed installation models connect with 20mm copper tube and an AGA approved isolating ball valve. For models fitted with lockable wheels/castors an Australian certified stainless steel braided flexible hose of adequate internal diameter must be used. The fitting of the hose must comply with the relevant sections of gas installation code AS/NZS 5601. A restraining chain or wire must be fitted. We recommend a maximum length of 1.5 m for the flexible hose. When the appliance is in position all of the wheels/castors must have the built in lock on to prevent any movement of the appliance. An Australian certified isolating ball valve must also be fitted.

BEFORE CONNECTING NEW PIPE TO THIS APPLIANCE, THE PIPE MUST BE BLOWN OUT THOROUGHLY TO REMOVE ALL FOREIGN MATERIAL. FOREIGN MATERIAL IN THE BURNER AND GAS CONTROLS WILL CAUSE IMPROPER AND DANGEROUS OPERATION.

Connect to gas.

Pressure Test Point

All appliances that are dispatched from our factory are tested and adjusted according to the specifications for the required gas type. The regulator may require adjustment to achieve required gas pressure.

Check the burner pressure at the test point on the regulator. The test point pressure should be adjusted to 1.00 kPa – Natural gas or 2.60 kPa – LPG with the burners operating at maximum.

Water Connection

The water connection is 15mm copper and is situated at the rear of the appliance below the main body frame. The number of water inlets varies to client's particular needs. Water isolation valves are fitted to all water inlets. Ensure water is flushed through before final connection.

For all appliances installed with lockable wheels or castors, flexible hoses(according to Australian standards) should be used for water connection.

Water waste outlet is located on the left hand side of the waste gutter of the appliance (50mm connection). The water inlets and water drains should be connected with rigid copper pipes. **Plastic/PVC piping should not be used for connection of waste outlet which will void warranty if done so.**

Before Leaving - Commissioning

Check **all** connections for gas leaks with soap and water. **Do not** use a naked flame for detecting leaks.

Ignite the pilot and main burners as prescribed below to ensure correct operation of gas valves, burners and ignition. When satisfied with the operation of the appliance, please instruct the user on the correct method of operation. Ensure that this instruction manual is left with owner of the appliance.

Chimney burner

- A. Light the appliance by pressing in the flame safe guard (blue) button and while holding it in turn the

pilot burner knob anti-clockwise to "ON".

B. Light pilot manually.

C. Continue to hold in the flame safe guard button for about 25 to 30 seconds.

D. Observe whether the pilot is alight.

E. If not repeat steps **A.** to **D.**

F. If it is alight turn main burner valve anti-clockwise to the "ON" positions

G. Check that burner is properly alight.

Chimney Burners – Pilot Light Chimney Burner

A. Ensure pilot light head is located no further than 45mm from the injector located opposite the burner inlet.

In the event the appliance fails to operate correctly, check the following;

1. Data plate to ensure correct gas type and pressure (adjust if necessary)
2. Adjust aeration by adjusting air shutter located at the front of the venture of the main burner.
3. Injector sizes – check against data plate and installation manual
4. View pilot size and adjust if required.

In case appliance fails to operate correctly after all checks have been carried out, please contact;

B&S Commercial Kitchens Pty Ltd

57 Plateau Road

Reservoir VIC 3073

Tel.: + 61 3 9469 4754 Fax.: + 61 3 9469 4504 E-mail: info@bscommercialkitchens.com

Operating Instructions

WARNING



- **DO NOT** spray aerosols in the vicinity of this appliance while it is in operation.
- **DO NOT** store or use flammable liquids or items in the vicinity of this appliance.
- Prior to lighting, smell area surrounding the appliance for gas (please note that as some gas types are heavier than air, we recommended the operator to also smell the floor around the appliance).
- In the event you smell gas: **DO NOT** light any appliance. **DO NOT** touch/ operate any electrical switch or phone in your building. Call local gas supplier **immediately** and follow their instructions.

IMPORTANT WARNING!

ENSURE NO OR MINIMAL AMOUNTS OF OIL AND FOODSTUFFS FALL INTO THE BURNER AREA WHILST COOKING. FAILURE TO DO SO MAY AFFECT THE EFFICIENT AND SAFE OPERATION ON THE APPLIANCE AND **MAY VOID WARRANTY**

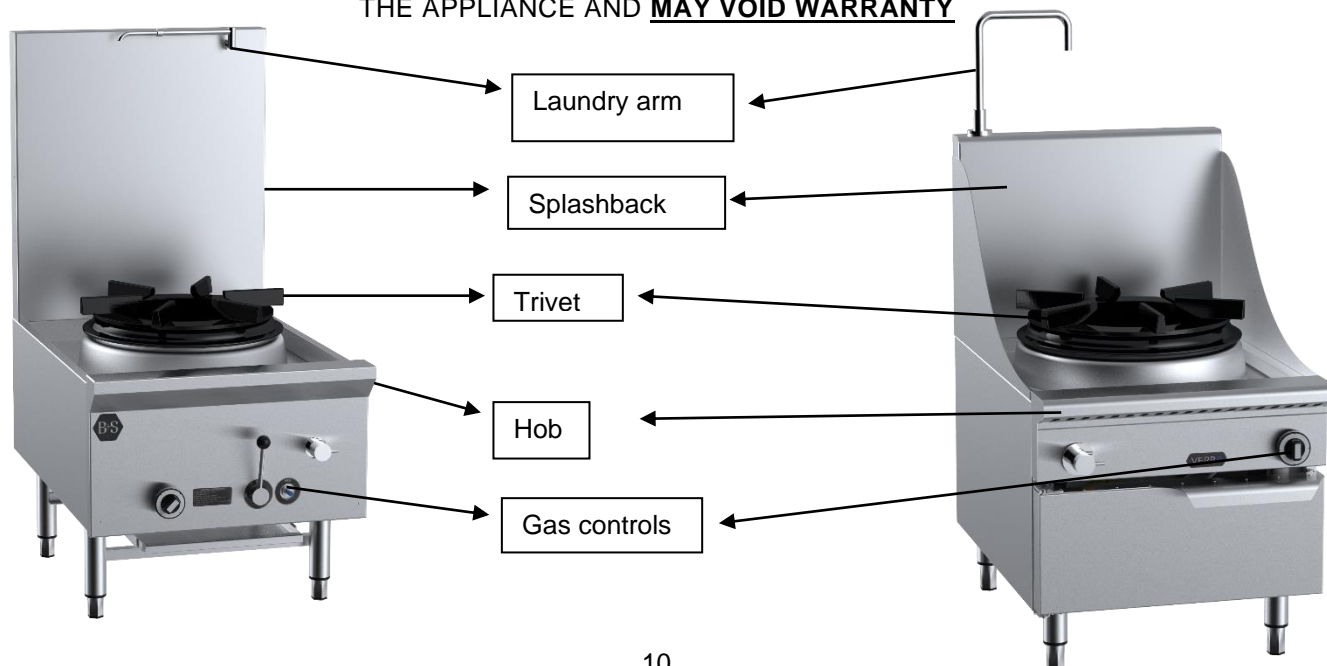

Lighting Instructions

1. Turn main gas valve to 'OFF'.
2. Turn pilot valve anti-clockwise to 'ON' position.
3. Depress blue button on flame failure control and manually ignite light pilot.
4. When pilot is alight, keep holding down the blue flame failure button for approximately 15 seconds.
5. Observe the pilot flame is established. **If pilot flame goes out wait five minutes and repeat steps 1 to 4.**
6. Turn main gas valve to 'HIGH' position.

Shutdown Procedure

1. Turn main gas valve to 'OFF'.
2. Turn pilot control valve clockwise to turn off.
3. Observe pilot flame is extinguished.

Telescopic Laundry Arm – Manual Control (Water Cooled Models)

The telescopic laundry arm serves the purpose for cleaning the appliance and for filling the stock pot cooking vessel with water to be used for cooking purposes. To activate;

1. Locate spindle on front panel with 'Spout' sticker located above it.
2. Turn spindle anti-clockwise to activate water from laundry arm.
3. To cease water flowing from laundry arm, turn 'Spout' spindle clockwise.

IMPORTANT WARNING!

NEVER LEAVE WATER RUNNING FROM TELESCOPIC LAUNDRY ARM WHILST POSITIONED OVER THE STOCK POT SUPPORT RING WITH NO POT/PAN POSITIONED ON IT. ALWAYS MOVE TELESCOPIC LAUNDRY ARM PARALLEL TO THE SPLASHBACK WHEN THE APPLIANCE NOT IN USE. DIRECT FLAME CONTACT WITH LAUNDRY ARM MAY DAMAGE OPERATION OF LAUNDRY ARM SPOUT.

Telescopic Laundry Arm Operation with Knee Valve – Where Fitted

The Laundry arm also serves the purpose of cleaning the appliance and/or for filling a stock pot vessel with water to be used for cooking purposes.

Flow cycle is actuated by deflection and release of the flow lever in any direction from the rest position. The adjustable flow rate automatically turns off with a non-concussive action after approximately 15 seconds. Closing time is not adjustable.

IMPORTANT WARNING!

IN THE EVENT OF FAILURE OF THE WOKSPOUT, WATER FLOW CAN BE CONTROLLED MANUALLY BY USING THE SPINDLE LOCATED ON FRONT PANEL (WHERE FITTED). WHERE NO SPINDLE FITTED, WATER SHOULD BE SWITCHED OFF FROM THE ISOLATION VALVE (WHICH IS RECOMMENDED TO BE FITTED WHEN INSTALLED) AND CONTACT AUTHORISED/ LICENSED SERVICE PERSONNEL.

Maintenance and Care

To ensure longevity and continued performance efficiency of you appliance, a good cleaning and maintenance program is paramount. In general the use of steel wool abrasive cloths/cleaners/powders **should not** be used to clean this appliance.

Daily Checks & Service

- Look for any foreign materials in burner area, leaks, damaged knobs and any other signs that the stock pot table is not ready and safe for operation. Inspect burner area and ensure pilots are in position near the burner, and that the pilot flame when ignited is blue in color and approximately 20-40mm in length. If fitted with thermocouple ensure pilot flame is in contact with it. Call the manufacturer if you see any problems. Always ensure that area surrounding pilot and thermocouple is clear of any fats, oils or foodstuffs.

- Clean the exterior surfaces of the stock pot with a clean, damp cloth soaked with mild detergent to remove any food stuffs, oils, dust and any other materials.
- Ensure the primary water drain (located in gutter) is cleared of any food stuffs during operation of the appliance and on completion of use of the appliance.
- The spillage trays located under the main body of the appliance should be removed (by pulling out) and any carbonized foodstuffs and oils should be removed using a clean, damp cloth soaked in a mild detergent.

Yearly Checks & Service

- **The appliance should be inspected and adjusted periodically by a qualified service person as part of any kitchen maintenance program.**
- **B&S recommends that this appliance is inspected at least annually by an authorized service technician as follows:**
 - Inspect the table inside-out for excessive build-up of any fats, oils and foodstuffs.
 - Inspect that the burners and other components (i.e. pilots, thermocouples, etc.) are in good condition and functioning properly.
 - Inspect all gas connections for leaks and ensure all connections are tightened properly.
 - Ensure burner manifold pressure is in accordance with that specified on the data plate of the appliance.
 - Inspect all gas connections for leaks and ensure all connections are tightened properly.

In case of difficulties, contact B&S Commercial Kitchens Pty Ltd or their authorized service agent.

Servicing Instructions



WARNING!

- Servicing shall be carried out by authorized personnel **only**. Failure to do so will void the B&S warranty and may result in damage to equipment or injury to personnel.
- Before commencing any disassembly/ assembly of gas controls, please ensure the gas supply is turned off (isolated).

FAILURE TO DO SO WILL VOID B&S WARRANTY AND MAY RESULT IN DAMAGE TO EQUIPMENT OR INJURY TO PERSONNEL.

Abnormal Operation

Any of the following are considered to be abnormal operation and may require servicing;

- Incomplete ignition of burner/burner failing to keep alight.
 - Check burner is not blocked.
- Yellow tipping of the burner flame.
 - Check aeration of burner.
- Gas valves which are difficult to turn.
- Burner failing to keep alight.

Gaining Access to Gas and/or Water System

To gain access to gas system/components;

1. Undo nut (by turning anti-clockwise) located on the front of the flame failure valve (blue button).
2. Remove knob off pilot valve by gently pulling forward.
3. Remove nut located centrally on the main gas valve (red handle).
4. Remove knee valve wand by unscrewing from main body of knee valve (where fitted).
5. Where deck cooling is fitted remove water spindle control by;
 - a. Unscrewing cold button on spindle.
 - b. Gently remove dome handle by gently pulling forward.
 - c. Unscrew flange by turning anti-clockwise.
 - d. Unscrew water spindle by turning anti-clockwise (ensure spindle washer is removed).
6. Remove screws located on bottom corners of front panel. Ensure any screws located on the inside of the gutter panel are also removed.

7. Gently pull front panel outwards from the bottom and lift front panel upwards.
8. REASSEMBLE IN REVERSE ORDER.

Removal of Burner for Service

Follow procedure described under GAINING ACCESS TO GAS AND/OR WATER SYSTEM;

1. Undo barrel union located at in the centre of the gas manifold.
2. Remove burner support screw by undoing wing-nut located on the bottom front of the appliance frame.
3. Gently lift burner upwards slightly and pull burner outwards.
4. REASSEMBLE IN REVERSE ORDER.

Pilot and Flame Safeguard

Access to pilot assembly is gained by removing the wing-nut located to the left of the pilot assembly which secures it to the burner support bar, and gently pull forward to gain greater access (refer picture).

1. To service/remove the thermocouple;
 - a. Undo the nut located underneath and above the thermocouple at the pilot assembly and gently pull thermocouple downwards.
 - b. Remove thermocouple from flame failure valve by unscrewing.
 - c. Reassemble in reverse order.
2. To service/remove pilot burner;
 - a. Undo nut located underneath the pilot burner on the pilot assembly.
 - b. Gently pull down pilot flexible gas tube.
 - c. Remove injector from pilot and clean (if required).
 - d. Reassemble in reverse order.
3. REASSEMBLE IN REVERSE ORDER.

Adjustments

Pilot

1. Remove front panel as described under GAINING ACCESS TO GAS CONTROL.
2. To increase gas pressure to pilot, turn adjustment screw located at the top right hand side of the flame failure device anti-clockwise.
3. To decrease gas pressure to pilot, turn adjustment screw located at the top right hand side of the flame failure device clockwise.
4. REASSEMBLE IN REVERSE ORDER ENSURING POSITION OF PILOT IS AS FOLLOWS;
Ensure pilot light head is light head is located no further than 45mm from the injector located opposite the burner inlet.

Servicing Wok Spout – Where Fitted

The Wok Spout has a few wearing parts and these comprise a single flow control O-ring in the tap body and two sealing O-rings on the swivel spout. Whilst it is expected that servicing would only be required at approximately 200,000 cycles, it recommended that a preventative service be carried out every two years. Please contact manufacturer for service kit.

Servicing Knee Valve – Where Fitted

The knee valve incorporates a cartridge design for ease of service.

1. Follow procedure described under GAINING ACCESS TO GAS AND/OR WATER SYSTEM
2. To gain access to knee valve cartridge undo knee valve where the deflector meets the cartridge area.
3. REASSAMBLE IN REVERSE ORDER.

Gas Type Conversion

The following parts componentry require changing the appliance from NG to LPG (vice-versa);

1. Regulator.
2. Burner.
3. Pilot.

In case of any failure in the functioning of the knee valve, unscrew the head assembly and clean the

mechanism under running water. Only use liquid cleaning products. All cleaning products containing dry powder or powder in suspension are not to be used!

A specific device is integrated in the cartridge unit to adjust the flow rate. To adjust the flow rate;

1. Undo head assembly
2. Pull off flow adjustor
3. On the exposed end of the housing there are 4 cut-outs for alternative flow rates.
4. Select one for increased/reduced flow.
5. Replace flow adjustor with window over selected cut-out.
6. Screw head assembly into the tap body and tighten fully.

Table 5: Troubleshooting

FAULT	POSSIBLE CAUSE	CHECKS
Pilot light not igniting	Blockage of pilot	Check pilot injector is not blocked as described in servicing instructions - pilot and flame safeguard
	Adjustment of pressure from flame control	Check gas pressure to pilot as described under servicing instruction - adjustments
Pilot light not establishing	Positioning of thermocouple	Check connection of the thermocouple to the control is not loose Adjust positioning of thermocouple to ensure pilot flame is hitting thermocouple
	Faulty thermocouple	Contact manufacturer or authorized service agent
	Faulty flame failure control valve	Contact manufacturer or authorized service agent
Pilot established, main burner not lighting	Faulty thermocouple	Contact manufacturer
	Faulty flame failure control valve	Contact manufacturer
Telescopic laundry arm constantly running (on water/deck cooled stock pot table)	Worn tap washer	Change washers in tap assembly
	Faulty 'O' ring in Wok spout	Contact manufacturer or authorized service agent
Wokspout constantly running water when in 'OFF' position	Faulty 'O' ring in Wok spout	Changing of 'O' ring as per service kit and instructions provided with appliance
	Faulty knee valve	Contact manufacturer or authorized service agent
Short/long laundry arm constantly running (when fitted with timer operated knee valve)	Faulty knee valve	Changing of knee valve cartridge
	Faulty knee valve cartridge	Contact manufacturer or authorized service agent

To obtain further service information concerning this appliance, please contact;

B&S Commercial Kitchens Pty Ltd

57 Plateau Road

Reservoir VIC 3073

Tel.: + 61 3 9469 4754

Fax.: + 61 3 9469 4504

E-mail: info@bscommercialkitchens.com



STANDARD WARRANTY CONDITIONS

B&S Commercial Kitchens Pty Ltd of 57 Plateau Road, Reservoir, Victoria (hereinafter called 'B&S') undertakes by this warranty, that B&S or its agent will pay for the cost of labour and parts which B&S or its agent find defective for:

K+ Range - eighteen (18) months from date of installation/hand over for projects.

B+S Black Range – twenty four (24) months from date of installation/hand over for projects.

Verro Range – thirty six (36) months from date of installation/hand over for projects.

The liability of B&S under this warranty is limited to the repair or replacement of defective goods or components. All other costs including, without limitation, cartage, carriage and installation shall be borne by the purchaser.

IMPORTANT

Prior to requesting a service call, please be sure that cooking equipment is being used and maintained in accordance with the instruction manual provided with your cooking equipment. Please also be sure that your cooking equipment has been installed in accordance with the manual by a qualified installer. All cooking equipment must be commissioned by installer upon completion of installation. Failure of these procedures will result in non-warranty service costs.

Warranty labour is supplied free of charge during business hours (8 a.m. to 4 p.m. AEDST) Monday to Friday. Should warranty work be requested outside of our normal working hours, a labour charge will be applied equivalent to a normal hour rate, with out of hours penalty rates. Penalty rates amount must be borne by the purchaser. Claims for non-covered parts, no faults found, travel over 100km or other items outside our standard terms and conditions will be chargeable. Note: Any extra time spent on site due to required inductions etc. is not covered by warranty.

1. This warranty applies only for mainland Australia and Tasmania, and does not cover any service consequent upon accident, alterations, misuse, fire, flood or act of God. Warranty for New Zealand is twelve (12) months parts and labour for K+, B+S Black & Verro Ranges.
2. This warranty is valid only if the appliance has been installed in accordance with local regulations by a duly authorised person, and the B&S installation instructions provided with the appliance. If in doubt, please contact B&S or their representative for further information. No responsibility will be accepted for defects or damages by improper installation, for changes to the product not authorised by B&S or for the operation outside the technical specifications of the appliance.
3. This warranty is conditional upon the appliance being used in normal commercial catering operations.
4. This warranty is the only express warranty given by the Company. No person has authority to change or to add to these obligations and liabilities.
5. The Company has the right to determine whether or not a fault is caused by faulty workmanship or material or that any part is defective.
6. This warranty does not apply to any loss suffered through or resulting from the non-operation or the ineffective operation of the cooking appliance or any part of the cooking appliance.
7. This warranty does not extend to goods and components thereof manufactured either entirely or substantially of glass or similar substances, light globes, infrared or quartz tubes and electrical controls or elements.
8. While the goods are in custody of the seller for investigation or repair, they shall be at the risk of the purchaser and no liability shall attach to the Company, its servants or agents for any damage occasioned to, or loan of, the goods whatsoever.
9. All warranties are non-transferable and are only applicable to the original end user (purchaser).
10. All warranty work must be carried out by a B+S approved service technician.

The Purchaser must give notice to the Company immediately upon it becoming aware of the alleged defect and in any event before the expiration of the appropriate warranty period.

B+S will endeavour to have a service technician on site for all warranty service requests within a 24 hour period or by end of next business day at the latest. All warranty requests must be in writing by either lodging a warranty request through B+S website or be emailing clientservices@bscommercialkitchens.com. Details of installer such as contact name, business name, telephone number and license number must be provided to avoid any delays.

11. Nothing in this warranty, however, shall be construed as affecting any rights you may have under the Trades Practices Act or any other Commonwealth or State Legislation which gives you rights which cannot be modified or excluded by agreement.

12. SPECIAL PROVISIONS – NOT COVERED BY WARRANTY

- Cleaning of spark and ignition sensors is not covered by warranty. Damage caused by oils, water and foodstuffs falling into burners or pilots will not be covered under warranty.
- Cleaning of burners due to blockage of burner orifices caused by foodstuffs and/or oils is not covered by warranty.
- Breakage of pilot knobs, knee valve handles and knee wands are not covered under warranty.
- Thermocouples, piezo leads and ignitors are only covered by twelve (12) months parts and labour across K+, B+S Black and Verro ranges.

- Seizure of gas cocks and knobs.
- Cleaning of blocked drains.
- Damage caused by lime scale and/or corrosion.
- Parts not supplied by B+S or a B+S authorised service technician.
- Damage caused by rodents and insects.
- Scheduled general maintenance.
- Normal wear and tear of parts
- Filters for DSK Deck Steamers

Additional costs are payable for:

Accommodation, cost of transport such as flights/ferries, poor access and waiting times.

B+S Commercial Kitchens
57 Plateau Road, Reservoir Victoria 3073 Australia
+61 3 9469 4754 | info@bscommercialkitchens.com | bscommercialkitchens.com